

10ft. CORD  
NEMA 4 MELTRIC  
PLUG  
110V / 1PH

ELECTRIC MOTOR  
90W TEFC  
230V 3 PH  
35-350 RPM OR  
60-600 RPM

OPTIONAL  
SPEED  
CONTROLLER  
NEMA 4X  
W/ DIGITAL  
DISPLAY

9.0"

6.0"

4.25"

AUTOCLAVABLE  
BEARING HOUSING  
WITH QUICK RELEASE  
MOTOR COUPLING

3/4" SHAFT  
316L ST.ST.

2" TC  
316L ST.ST.

DUAL LIP / LIP SEAL  
USP CLASS VI - ANIMAL FREE RULON  
WITH USP CLASS VI EPDM  
O'RING  
PN: VP-33-008-N-72-EP

FMB= 48.0"  
FL=50.81"

- NOTES:**
1. MTRS SUPPLIED + GOLD GMP DOCUMENT PACKAGE
  2. 32RA POLISH ON WETTED METAL PARTS
  3. 2" TC CLAMP & USP CLASS VI EPDM GASKET INCLUDED
  4. MIXER RUN TEST INCLUDED

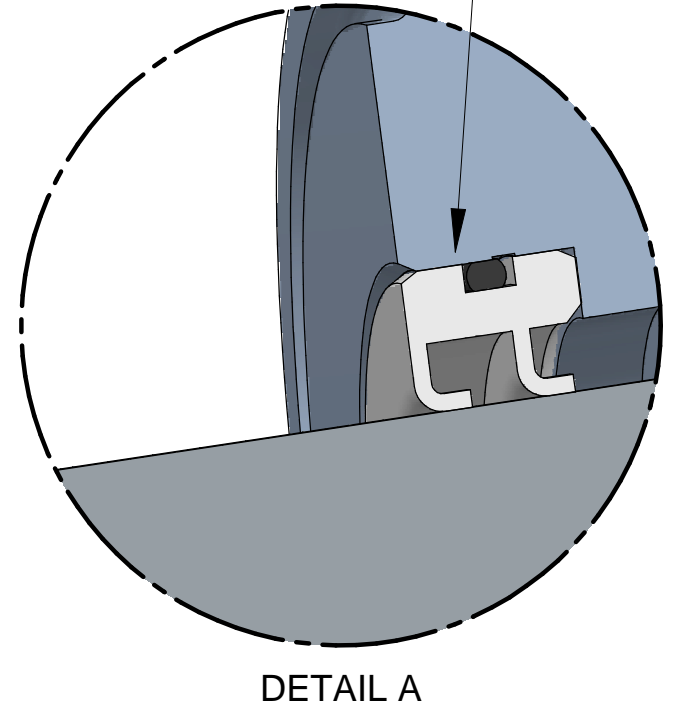

DETAIL A

5" BIOPROP  
316L ST.ST.  
< 32 RA  
SET SCREWED

MODEL:WMP-BB-90W

- OPTIONS**
- ELECTROPOLISH
  - 200WATT MOTOR
  - ANY CUSTOMIZATION

CUSTOMER:		
LOCATION:		
PRODUCT:		PRESSURE:
TEMP:		SPEED:
	SIZE	SERIAL NO.



WWW.WMPROCESS.COM

DWG NO. **MA1041**