

MECHANICAL SEAL WITH PLAIN GLAND CONCEPT DRAWING

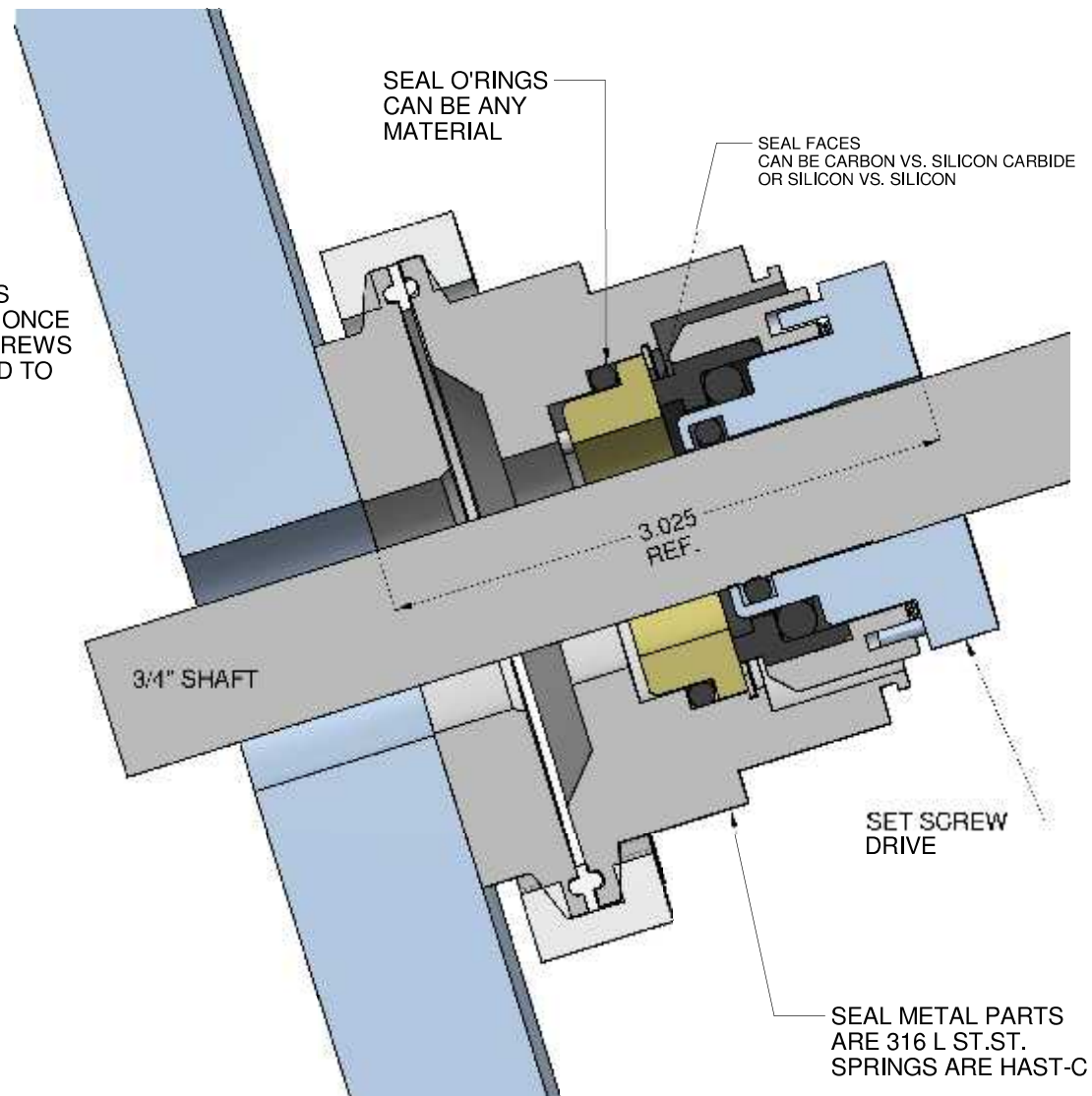
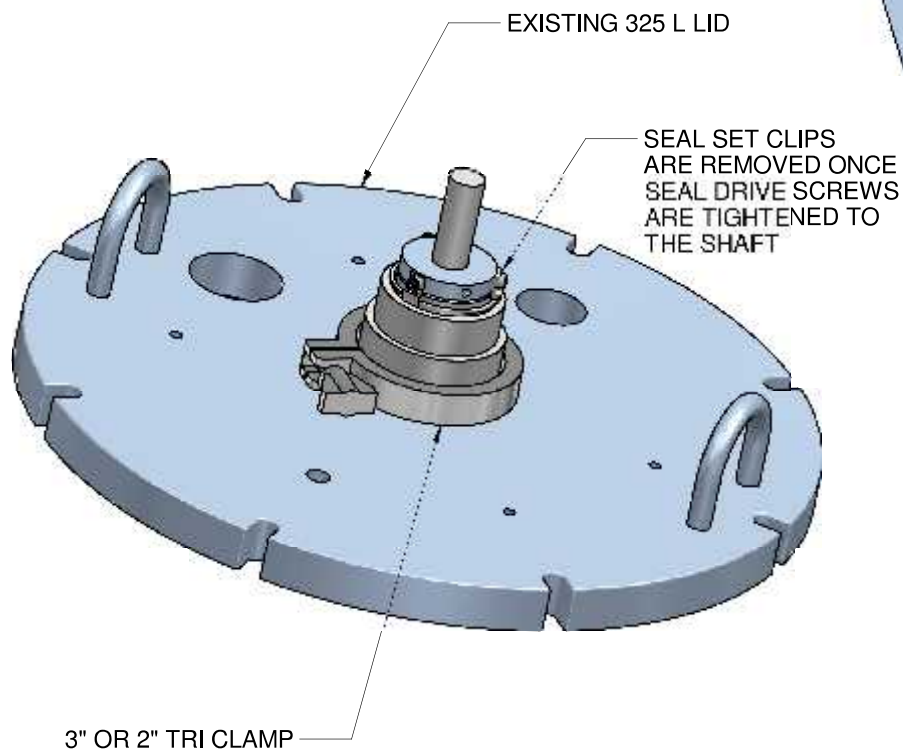

CUSTOMER:

LOCATION:

PRODUCT:

PRESSURE:

TEMP:

SPEED:

SIZE

SERIAL NO.

DWG NO.



WWW.WMPROCESS.COM