

# MECHANICAL SEAL WITH DEBRIS WELL CONCEPT DRAWING

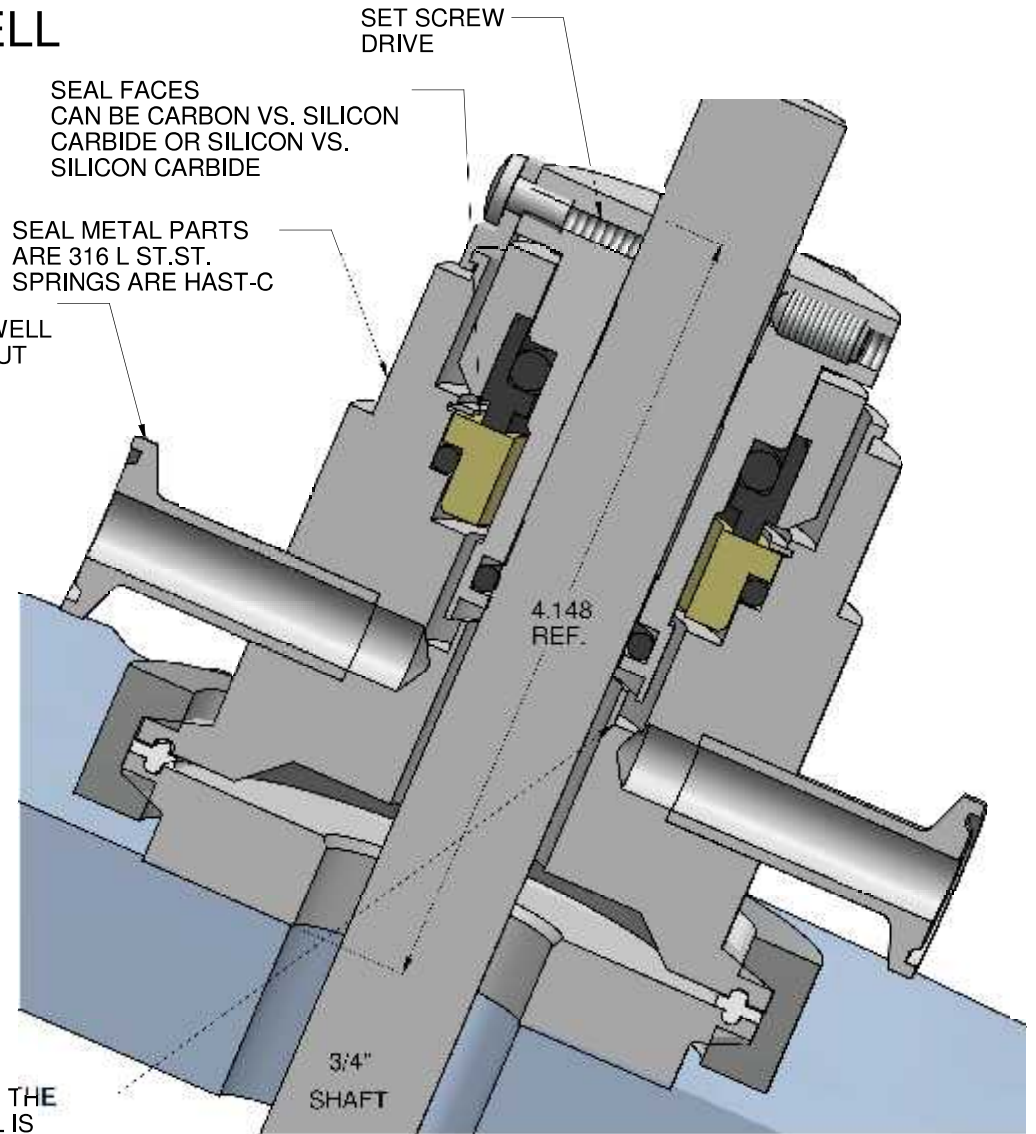

ANY DEBRIS FROM THE MECHANICAL SEAL IS CAPTURED HERE

CUSTOMER:	
LOCATION:	
PRODUCT:	PRESSURE:
TEMP:	SPEED:
SIZE	SERIAL NO.

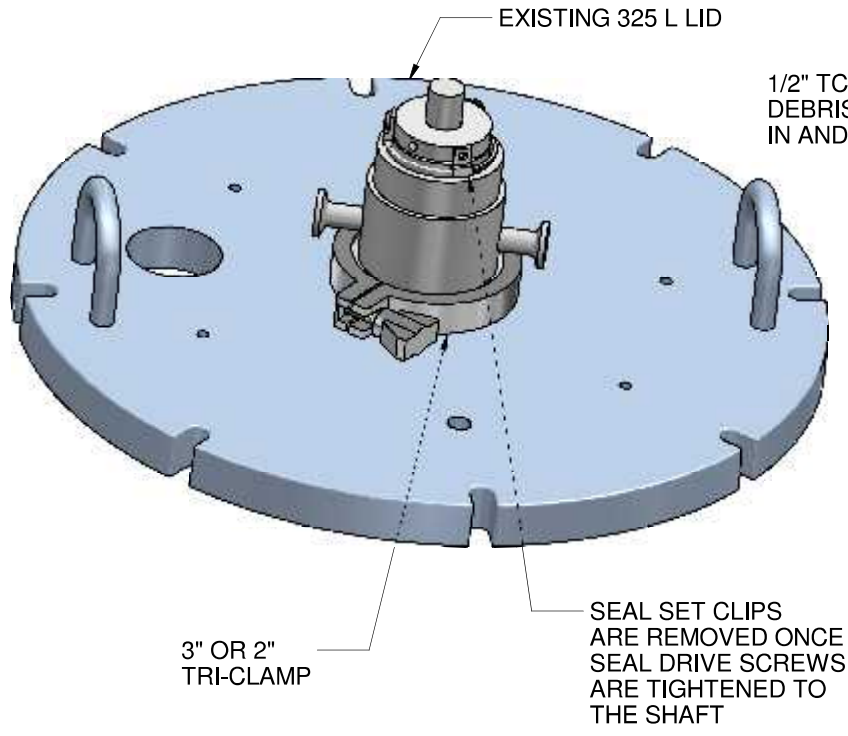

[WWW.WMPROCESS.COM](http://WWW.WMPROCESS.COM)

DWG NO.